

## Middle School Summer Reading

### 6th grade English

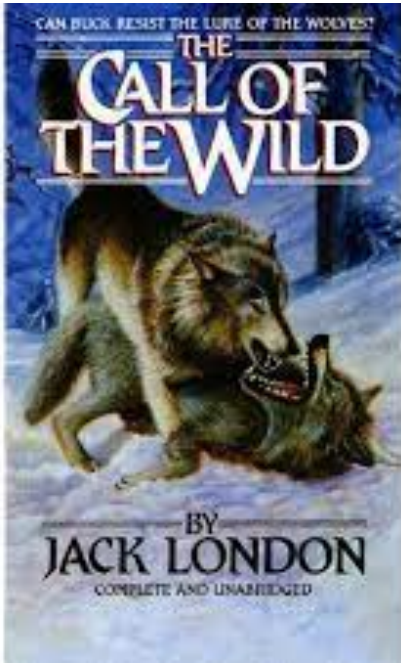

**Read:** *The Call of the Wild* by Jack London. Complete the attached Reading Response activities: Plot Structure and Making Inferences. Bring both assignments to class on Thursday, August 8.

### 6th Grade Math

#### **Assignment:**

Complete the following math packet. It is suggested that you complete one page per week. Bring the completed packet with you to school on Thursday, August 8.

---

(student's name)

**Rising**  
**6<sup>th</sup> grade**

**summer**  
**math packet**  
**2024**

**Fluency Blast**

Practice using mental math.

$1.2 \times 10$

$0.28 \times 100$

$5.7 \times 1,000$

$1.04 \times 100$

$0.16 \times 100$

$2.8 \times 1,000$

$2.4 \times 10$

$100 \times 1.2$

$3.05 \times 10$

$3.4 \times 1,000$

**Day 1**

1.  $\frac{1}{3} + \frac{2}{12} =$  \_\_\_\_\_

2.  $4\frac{1}{8} + 5\frac{3}{4} =$  \_\_\_\_\_

3. 
$$\begin{array}{r} \frac{1}{2} \\ - \frac{1}{6} \\ \hline \end{array}$$

4. Tia has two packages to mail. Her packages weigh  $6\frac{1}{8}$  pounds total. If Tia's first package weighs  $4\frac{1}{2}$  pounds, how many pounds does her second package weigh?
- \_\_\_\_\_

**Day 2**

Write the matching expressions.

1. 5 times the sum of 3 and itself

\_\_\_\_\_

2. 6 increased by 14 divided by 7

\_\_\_\_\_

3. 2 times 3 plus 9

\_\_\_\_\_

4. 2 less than the product of 5 and 9

\_\_\_\_\_

5. 6 less than the sum of 77 and 17, halved

\_\_\_\_\_

**Day 3**

1. Ms. Ferris owns a barn that is 12 yards long, 11 yards wide, and 9 yards high. If Ms. Ferris's barn is rectangular, what is the volume of the barn? \_\_\_\_\_
2. A toy doll was sent to Lucy in a box that is 8 inches long, 5 inches wide, and 15 inches high. What is the volume of the box?
- \_\_\_\_\_
3. A swimming pool is 8 meters in length, 6 meters in width, and 3 meters in depth. What is the volume of the swimming pool?
- \_\_\_\_\_

**Day 4**

Give two examples of polygons that share the attributes.

1. 4 right angles \_\_\_\_\_

\_\_\_\_\_

2. at least one pair of parallel sides \_\_\_\_\_

\_\_\_\_\_

3. at least one right angle \_\_\_\_\_

\_\_\_\_\_



**Fluency Blast**

Practice using mental math.

$$\begin{array}{r} 0.2 \\ \times 4 \\ \hline \end{array}$$

$$\begin{array}{r} 0.08 \\ \times 6 \\ \hline \end{array}$$

$$\begin{array}{r} 0.7 \\ \times 9 \\ \hline \end{array}$$

$$\begin{array}{r} 0.14 \\ \times 2 \\ \hline \end{array}$$

$$\begin{array}{r} 0.06 \\ \times 4 \\ \hline \end{array}$$

$$\begin{array}{r} 0.8 \\ \times 3 \\ \hline \end{array}$$

$$\begin{array}{r} 0.04 \\ \times 5 \\ \hline \end{array}$$

$$\begin{array}{r} 0.2 \\ \times 6 \\ \hline \end{array}$$

$$\begin{array}{r} 0.5 \\ \times 4 \\ \hline \end{array}$$

$$\begin{array}{r} 0.3 \\ \times 5 \\ \hline \end{array}$$



**Day 1**

1.  $\frac{1}{4} \div 3 =$  \_\_\_\_\_

2.  $\frac{4}{6} \times \frac{3}{5} =$  \_\_\_\_\_

3. Brandy has 8 pounds of candy. She wants to give each of her friends  $\frac{1}{3}$  pound. To how many friends can Brandy give candy?  
\_\_\_\_\_

4. Stephan can mow  $2\frac{1}{2}$  acres of lawn in 1 day. How many acres of lawn can he mow in  $2\frac{1}{3}$  days? \_\_\_\_\_

**Day 2**

1. Trolley cars are carrying 1,845 passengers. Each trolley car can hold 40 passengers. How many trolley cars are needed to hold all of the passengers? \_\_\_\_\_

2. Seth drove 129 minutes on Monday. He drove 98 minutes on Tuesday and 73 minutes on Wednesday. How many hours did Seth spend driving altogether? \_\_\_\_\_

3. Brianna buys 5 yards of blue fabric. Then, she buys 2 feet of red fabric and 4 feet of green fabric. How many inches of fabric does Brianna buy altogether? \_\_\_\_\_

**Day 3**

Find the volume of each figure.

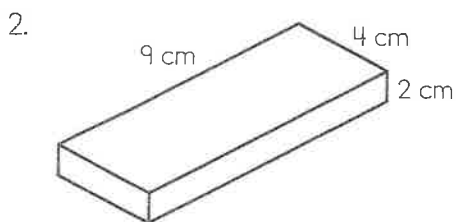
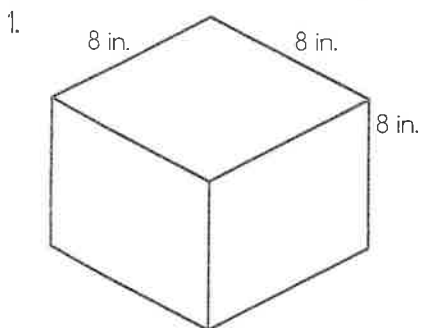

**Day 4**

Graph the coordinates. Connect them in the order they are listed.

1. (2, 5) and (2, 1)

2. (2, 5) and (4, 3)

3. (4, 3) and (6, 5)

4. (6, 5) and (6, 1)

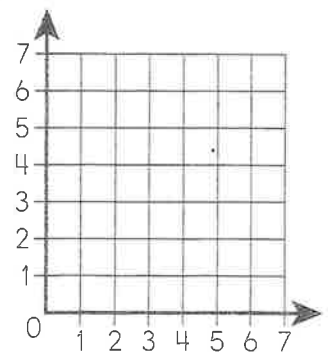

5. What letter did you make? \_\_\_\_\_

Name \_\_\_\_\_



**Fluency Blast**

Practice using mental math.

$9 \overline{)2.7}$      $7 \overline{)2.1}$      $4 \overline{)0.16}$      $8 \overline{)5.6}$      $6 \overline{)0.30}$      $8 \overline{)0.64}$      $9 \overline{)0.27}$      $7 \overline{)0.28}$      $3 \overline{)2.7}$      $9 \overline{)5.4}$



**Day 1**

1. Write **45.678** in expanded form.

\_\_\_\_\_

2. \_\_\_\_\_ thousands = 5,000 ones

3. Round **33.01** to the nearest tenth. \_\_\_\_\_

4. Compare the numbers using  $<$ ,  $>$ , or  $=$ .

$0.293$  ○  $0.29$

5.  $3.5 \times 10^4 =$  \_\_\_\_\_

**Day 2**

1.  $90 - (3 + 9) \times 7 =$  \_\_\_\_\_

2. Write a matching expression for *double the product of 6 doubled*.

\_\_\_\_\_

3. Sean is packaging tennis balls. He puts 3 tennis balls each into 150 packages and 5 tennis balls each into 75 packages. He has 2 tennis balls left over. How many tennis balls did Sean start with?

\_\_\_\_\_

**Day 3**

Find the volume of each figure.

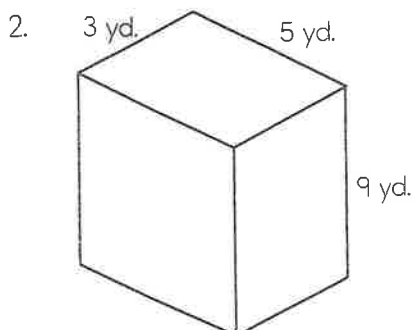
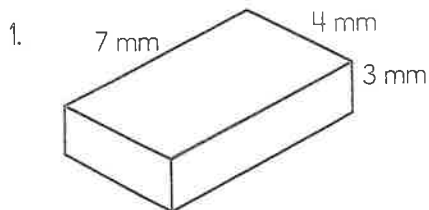

**Day 4**

Graph and label each ordered pair.

1. A (4, 4)

2. B (5, 2)

3. C (3, 3)

Identify the following points found on the graph.

4. D (\_\_\_\_\_, \_\_\_\_\_)

5. E (\_\_\_\_\_, \_\_\_\_\_)

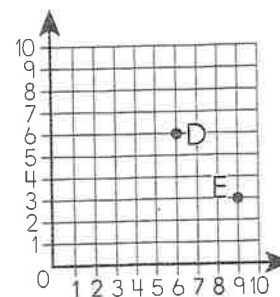



**Fluency Blast**

Practice using mental math.

- $3 \overline{)1.8}$      $2 \overline{)0.12}$      $9 \overline{)7.2}$      $7 \overline{)0.35}$      $4 \overline{)0.24}$      $5 \overline{)2.5}$      $4 \overline{)0.36}$      $9 \overline{)6.3}$      $6 \overline{)4.8}$      $8 \overline{)0.56}$



**Day 1**

- $2.7 \div 9 =$  \_\_\_\_\_
- $$\begin{array}{r} 56.14 \\ \times \quad 4 \\ \hline \end{array}$$
- The height of the water in a barrel is 49.27 centimeters. After one month, due to evaporation, the height of water in the barrel is 29.52 centimeters. How much did the water decrease in height during the month?  
\_\_\_\_\_

**Day 2**

Dave checks out 4 books from the library every other week. He likes to keep track of how many books he has read.

- Complete the table.

Weeks	Number of Books
1	4
3	
5	
7	
9	

- How many books will Dave have read in week 15? \_\_\_\_\_

**Day 3**

Elizabeth is making costumes for the school play. She finds scrap ribbon that she might be able to use and enters the lengths on the line plot below.

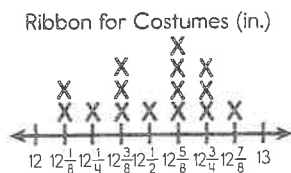

- How many pieces of ribbon does she have?  
\_\_\_\_\_
- Elizabeth needs 12 pieces of ribbon that are at least  $12\frac{1}{2}$  inches long each. Does she have enough for the costumes? \_\_\_\_\_
- If she needed 13 pieces of ribbon, how long would the shortest piece be? \_\_\_\_\_

**Day 4**

- Graph the information from the table on day 2.

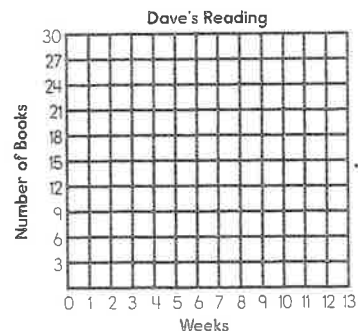

Answer the questions based on the pattern you see in the graph.

- In what week will Dave have read 25 books?  
\_\_\_\_\_
- In what week will he have read 40 books?  
\_\_\_\_\_



**Fluency Blast**

Practice using mental math.

$3.67 \times 10^4$

$68 \div 10^3$

$11.4 \times 10^2$

$5.9 \div 10$

$21.24 \times 10^3$

$8.6 \div 10^2$

$7.8 \times 10$

$9.21 \div 1$

$13 \times 10^3$

$10.5 \div 10^2$



**Day 1**

1.  $10 - \frac{1}{2} =$  \_\_\_\_\_

2.  $\frac{4}{5} + \frac{1}{10} =$  \_\_\_\_\_

3.  $\frac{5}{6} \times \frac{1}{5} =$  \_\_\_\_\_

4. Benjamin added  $1\frac{2}{3}$  cups of flour to his mixing bowl and then realized he had put in too much. He took  $\frac{1}{4}$  cup of the flour out of the bowl. How much flour did Benjamin's recipe call for?

\_\_\_\_\_

**Day 2**

Write the matching expressions.

1. 6 times 4 plus 3 times 4

\_\_\_\_\_

2.  $\frac{1}{4}$  times 8 increased by 11

\_\_\_\_\_

3. the sum of 10 and 12 divided by 2

\_\_\_\_\_

4.  $\frac{1}{2}$  of 8 minus 2

\_\_\_\_\_

**Day 3**

Find the volume.

1.  $l = 4$  centimeters  
 $w = 6$  centimeters  
 $h = 2$  centimeters  
 $V =$  \_\_\_\_\_ cubic centimeters

2.  $l = 10$  centimeters  
 $w = 8$  centimeters  
 $h = 3$  centimeters  
 $V =$  \_\_\_\_\_ cubic centimeters

**Day 4**

Draw each polygon. Then, list its attributes.

1. trapezoid \_\_\_\_\_  
 \_\_\_\_\_  
 \_\_\_\_\_  
 \_\_\_\_\_
2. rhombus \_\_\_\_\_  
 \_\_\_\_\_  
 \_\_\_\_\_  
 \_\_\_\_\_
3. parallelogram \_\_\_\_\_  
 \_\_\_\_\_  
 \_\_\_\_\_  
 \_\_\_\_\_



**Fluency Blast**

Practice using mental math.

$6.29 \times 10^4$        $106 \div 10^3$        $14.83 \times 10^2$        $6.84 \div 10$        $3.48 \times 10^3$   
 $2.437 \div 10^2$        $17.748 \times 10$        $28.15 \div 1$        $5.49 \times 10^3$        $406.9 \div 10^2$



**Day 1**

- $4 \div \frac{1}{2} =$  \_\_\_\_\_
- $\frac{1}{2} \times \frac{6}{9} =$  \_\_\_\_\_
- Find the area of a rectangle with a length of  $12\frac{1}{5}$  feet and a width of  $4\frac{2}{15}$ . \_\_\_\_\_
- Beth measured  $1\frac{2}{3}$  quarts of cherries. She realized she only needed half of that amount. How many quarts of cherries does Beth need?  
\_\_\_\_\_

**Day 2**

- $(1.8 \times 0.5) \times (3.4 + 2.6) =$  \_\_\_\_\_
- Rudy's little brother packs 7 toys in his bag. The bag itself weighs 3 ounces. If each toy weighs  $1\frac{3}{4}$  ounces, how many ounces does his bag weigh?  
\_\_\_\_\_
- Eric planted 647 bulbs in his garden. He had to plant the bulbs in rows of 20. How many rows was Eric able to plant?  
\_\_\_\_\_

**Day 3**

- Austin buys fencing for his square dog pen that measures 9 feet per side. How many inches of fencing does Austin buy altogether?  
\_\_\_\_\_
- Robert is making apple cider. If he makes 6 quarts, how many 1-cup servings can he pour?  
\_\_\_\_\_
- $59,600 \text{ mL} =$  \_\_\_\_\_ L

**Day 4**

Use the coordinate grid to answer the questions.

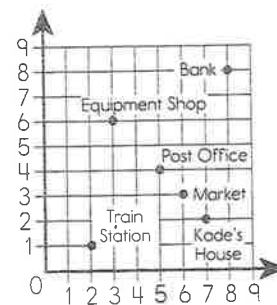

Write the coordinates for each location.

- Train Station (\_\_\_\_\_, \_\_\_\_\_)
- Market (\_\_\_\_\_, \_\_\_\_\_)
- Bank (\_\_\_\_\_, \_\_\_\_\_)
- What is one path that Kade could take to get from his house to the Equipment Shop?  
\_\_\_\_\_



Name \_\_\_\_\_



**Fluency Blast**

Practice using mental math.

$205.602 \times 10^4$

$18.0 \div 10^3$

$39.194 \times 10^2$

$38.52 \div 10$

$93.295 \times 10^3$

$15.4 \div 10^2$

$289.37 \times 10$

$309 \div 1$

$38.53 \times 10^3$

$18.3 \div 10^2$



**Day 1**

1. Compare the numbers using  $<$ ,  $>$ , or  $=$ .

$0.293 \bigcirc 0.29$

2. Write **five hundred six and twelve hundredths** in standard form. \_\_\_\_\_

3. Round **122.18** to the nearest whole number.  
\_\_\_\_\_

4. 9 tens = \_\_\_\_\_ ones

5.  $5.1 \times 10^4 =$  \_\_\_\_\_

**Day 2**

1.  $(16 - 7) - (2 \times 4) =$  \_\_\_\_\_

2. Write a matching expression for *4 added to 12 times 19 plus 24*. \_\_\_\_\_

3. Mr. Ortiz gives 9 sheets of paper each to the 6 groups in his math class. He gives 3 sheets of paper each to the 8 groups in his reading class. He has 15 sheets of paper left over. How many sheets of paper did Mr. Ortiz start with?  
\_\_\_\_\_

**Day 3**

1. 482 cg = \_\_\_\_\_ g

2. 51,000 mL = \_\_\_\_\_ L

3. Find the volume of the figure.

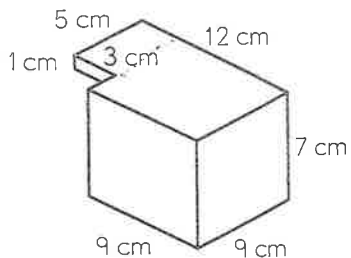

\_\_\_\_\_

**Day 4**

Graph and label each ordered pair.

1. A (3, 3)

2. B (7, 5)

3. C (5, 2)

Identify the following points found on the graph.

4. D (\_\_\_\_\_, \_\_\_\_\_)

5. E (\_\_\_\_\_, \_\_\_\_\_)

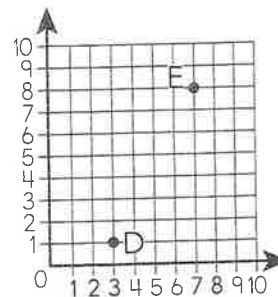



**Fluency Blast**

Practice using mental math.

$3 \div \frac{1}{5} =$  \_\_\_\_\_  $4 \div \frac{1}{6} =$  \_\_\_\_\_  $5 \div \frac{1}{3} =$  \_\_\_\_\_  $4 \div \frac{1}{5} =$  \_\_\_\_\_  $7 \div \frac{1}{9} =$  \_\_\_\_\_

$5 \div \frac{1}{4} =$  \_\_\_\_\_  $7 \div \frac{1}{8} =$  \_\_\_\_\_  $2 \div \frac{1}{5} =$  \_\_\_\_\_  $1 \div \frac{1}{5} =$  \_\_\_\_\_  $3 \div \frac{1}{3} =$  \_\_\_\_\_



**Day 1**

- $9.21 + 76.28 =$  \_\_\_\_\_
- $175 \times 65 =$  \_\_\_\_\_
- $24.50 \div 5 =$  \_\_\_\_\_
- $7.09 - 6.99 =$  \_\_\_\_\_
- Yvonne watched a video for 0.2 hours in the morning. At night, she continued watching the video for 0.87 hours. How much longer did she watch the video at night?  
\_\_\_\_\_

**Day 2**

Rachel's plant grew 2 inches a day.

- Complete the table.

Days	Growth (in.)
1	2
2	
3	
4	
5	

- How many inches will the plant have grown by day 8? \_\_\_\_\_

**Day 3**

- Rachel grew a second plant for her experiment. It did not grow the same amount each day. Every day was a different fraction of an inch. Plot the growth on the line plot.

$\frac{1}{8}, \frac{5}{8}, 1, \frac{1}{4}, \frac{1}{2}, \frac{1}{4}, \frac{5}{8}$



- How many days did Rachel measure the plant's growth? \_\_\_\_\_
- What was the average growth for the plant over the week? \_\_\_\_\_

**Day 4**

List the coordinates for each student's house.

- Amber's House  
(\_\_\_\_\_, \_\_\_\_\_)
- Lucy's House  
(\_\_\_\_\_, \_\_\_\_\_)
- Becky's House  
(\_\_\_\_\_, \_\_\_\_\_)
- Abe's House  
(\_\_\_\_\_, \_\_\_\_\_)

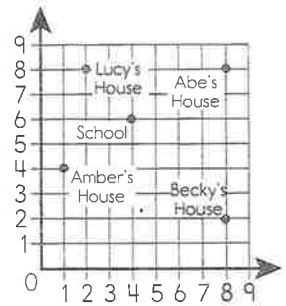

- Give a set of directions to get from Becky's house to Lucy's house. \_\_\_\_\_  
\_\_\_\_\_

Name \_\_\_\_\_



**Fluency Blast**

Practice using mental math.

$\frac{1}{5} \div 5 =$  \_\_\_\_\_  $\frac{1}{6} \div 3 =$  \_\_\_\_\_  $\frac{1}{3} \div 7 =$  \_\_\_\_\_  $\frac{1}{5} \div 2 =$  \_\_\_\_\_  $\frac{1}{3} \div 4 =$  \_\_\_\_\_

$\frac{1}{7} \div 5 =$  \_\_\_\_\_  $\frac{1}{5} \div 4 =$  \_\_\_\_\_  $\frac{1}{4} \div 6 =$  \_\_\_\_\_  $\frac{1}{3} \div 8 =$  \_\_\_\_\_  $\frac{1}{4} \div 7 =$  \_\_\_\_\_



**Day 1**

1.  $\frac{2}{3} + \frac{2}{13} =$  \_\_\_\_\_

2.  $\frac{6}{15} + \frac{9}{12} =$  \_\_\_\_\_

3.  $\frac{6}{13} - \frac{2}{6} =$  \_\_\_\_\_

4. Nina's recipe says to sift  $\frac{5}{8}$  teaspoon of baking powder with  $\frac{1}{3}$  teaspoon of salt. How many teaspoons does Nina sift altogether?

\_\_\_\_\_

**Day 2**

1.  $5 \times (5 - 3) =$  \_\_\_\_\_

2.  $20 - (4 \times 3) =$  \_\_\_\_\_

3.  $(7 \times 8) - (4 \times 9) =$  \_\_\_\_\_

4.  $8 + 6 \div 2 - 2 =$  \_\_\_\_\_

5.  $12 \div 2 + 15 - (144 \div 9) =$  \_\_\_\_\_

**Day 3**

1. A company measured its cereal box. What is the volume if the dimensions are 2 inches long, 14 inches high, and 3 inches wide? \_\_\_\_\_

2. A baby's block measures 12 centimeters on all sides. What is the block's volume? \_\_\_\_\_

3. A juice box measures 4 centimeters long, 10 centimeters high, and 5 centimeters wide. What is the volume of juice? \_\_\_\_\_

4. The dimensions of a toy box are 2 feet high, 2 feet wide, and 3 feet long. What is the box's volume? \_\_\_\_\_

**Day 4**

Complete the chart for quadrilaterals.

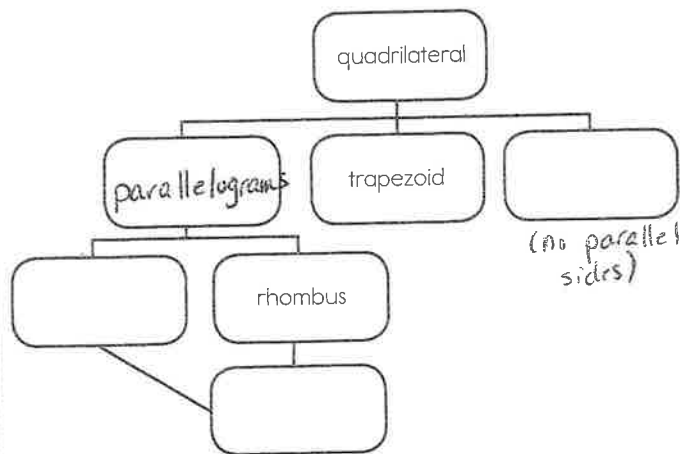



### Fluency Blast

Practice using mental math.

$\frac{1}{4} \div 8 = \underline{\hspace{2cm}}$      $12 \div \frac{1}{6} = \underline{\hspace{2cm}}$      $4 \div \frac{1}{8} = \underline{\hspace{2cm}}$      $\frac{1}{2} \div 4 = \underline{\hspace{2cm}}$      $\frac{1}{9} \div 3 = \underline{\hspace{2cm}}$   
 $\frac{1}{3} \div 9 = \underline{\hspace{2cm}}$      $8 \div \frac{1}{2} = \underline{\hspace{2cm}}$      $6 \div \frac{1}{3} = \underline{\hspace{2cm}}$      $\frac{1}{7} \div 4 = \underline{\hspace{2cm}}$      $4 \div \frac{1}{10} = \underline{\hspace{2cm}}$

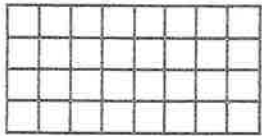

#### Day 1

- $\frac{3}{4} \div \frac{1}{2} = \underline{\hspace{2cm}}$
- $\frac{1}{3} \times \frac{2}{5} = \underline{\hspace{2cm}}$
- Shade the area on the grid that shows  $\frac{7}{8} \times \frac{3}{4}$ .  

- Of the shoes in Liza's closet,  $\frac{1}{2}$  are sandals. Of the sandals,  $\frac{1}{2}$  are brown. What fraction of Liza's shoes are brown sandals?  $\underline{\hspace{2cm}}$

#### Day 2

- The Equipment Shop sold 950 golf balls in buckets. If each bucket holds 100 golf balls, how many buckets did the store sell?  $\underline{\hspace{2cm}}$
- Jonathon's bakery has 1,294 cups of frosting. If each cake he frosts uses 2 cups of frosting, how many cakes can he frost?  $\underline{\hspace{2cm}}$
- Mrs. Irving's class ate  $\frac{1}{5}$  of their green pepper pizza and  $\frac{9}{12}$  of their pepperoni pizza. Which pizza did they eat more of? Explain.  $\underline{\hspace{2cm}}$   
 $\underline{\hspace{2cm}}$

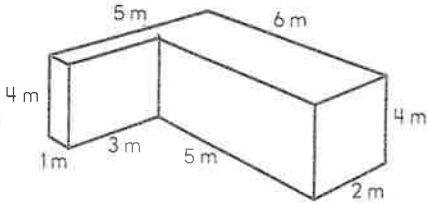
#### Day 3

- Find the volume.  
 $l = 4.5 \text{ m}$   
 $w = 3 \text{ m}$   
 $h = 8.5 \text{ m}$   
 $V = \underline{\hspace{2cm}}$
- Find the volume of the figure.  
  
 $\underline{\hspace{2cm}}$
- A new sandbox measures 12 feet long, 1 foot high, and 6 feet wide. What volume of sand can it hold?  $\underline{\hspace{2cm}}$

#### Day 4

- Graph the coordinates. Connect them in the order they are listed.  
 $(2, 6)$  and  $(4, 4)$   
 $(4, 4)$  and  $(6, 6)$   
 $(4, 4)$  and  $(4, 1)$
- What letter did you make?  $\underline{\hspace{2cm}}$

